



Electrical power supply

POLITERM[®] BLOW READY MIX



FAN FOR POLITERM[®] BLU READY MIX
LOADING IN CEMENT MIXER

POLITERM[®] BLOW READY MIX

Fan for politerm[®] blu ready mix loading in cement mixer

TYPE OF EQUIPMENT

Fan for the loading of Politerm[®] Blu Ready Mix into cement mixer.

Iron framework with:

- Engine's control panel.
- Transfer fan of the beads.
- Metal pipe for the beads loading with flexible top part.
- Wheels for the handling.
- Adjusting device for the loading pipe positioning.
- 20 m of power supply cable + industrial three-phase 16A plug.
- Phase inverter.

TECHNICAL CHARACTERISTICS

Power supply:	400 V
Voltage:	380 V
Power:	0,75 Kw
Weight :	300 kg
Hopper capacity:	760 L

TECHNICAL SCHEMA

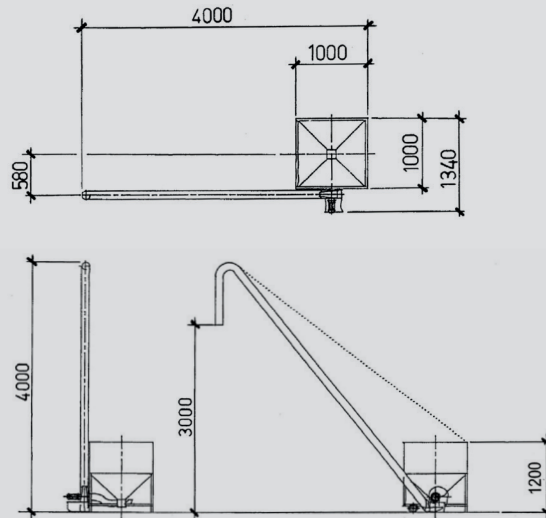

All the indications provided in this technical sheet are purely approximate and not binding for legal purpose. The data listed has been gathered from laboratory test and it hence follows that in practical applications on building sites the final products may be subject to variations depending on meteorological conditions and the installation. The user must always check suitability of the product for its specific use, undertaking all liability implicit in and deriving from use of the product, as well as comply with all methods and instruction for use generally referable to "workmanlike" execution. Edilteco S.p.A reserves the right to change the contents of this mechanical data sheet on its final judgment. The spreading of this data sheet through any media, supersedes and cancels the validity of any other technical data sheet previously published.



E&MP Engineering Machines Plants Division

DS POLITERM[®] BLOW READY MIX . Rev 08/2018 . GB



Edilteco S.p.A. Via dell'Industria, 710 . 41038 San Felice sul Panaro (MO) Italy
Ph. +39 0535 82161 . Fax +39 0535 82970 . www.edilteco.com | info@edilteco.com

© Copyright EDILTECO S.p.A. - Non authorized reproduction is forbidden.

COMPANY WITH
QUALITY SYSTEM
CERTIFIED BY DNV GL
= ISO 9001 =